



US 20110173867A1

(19) **United States**

(12) **Patent Application Publication**
Young

(10) **Pub. No.: US 2011/0173867 A1**

(43) **Pub. Date: Jul. 21, 2011**

(54) **ADJUSTABLE SUPPORT FOR FIREARMS**

(52) **U.S. Cl. 42/94**

(75) **Inventor: Nicholas E. Young, Murray, UT (US)**

(57) **ABSTRACT**

(73) **Assignee: DESERT MANUFACTURING, LLC, Salt Lake City, UT (US)**

An adjustable support for a firearm includes an extension shaft having a distal end, a proximal end, a central axis, and a plurality of engagement features formed at a plurality of axial locations between the distal end and the proximal end. A housing assembly is configured to house the extension shaft and defines a reference datum. At least one locking member is operatively associated with the housing assembly and is configured to selectively engage the engagement features. An actuator is operatively associated with the housing assembly such that translation of the actuator relative to the central axis moves the locking members into and out of engagement with the engagement features on the extension shaft. Rotation of the actuator relative about the central axis moves the distal end of the extension shaft away from the housing assembly.

(21) **Appl. No.: 12/688,696**

(22) **Filed: Jan. 15, 2010**

Publication Classification

(51) **Int. Cl.**
F41A 23/06 (2006.01)
F41C 27/22 (2006.01)

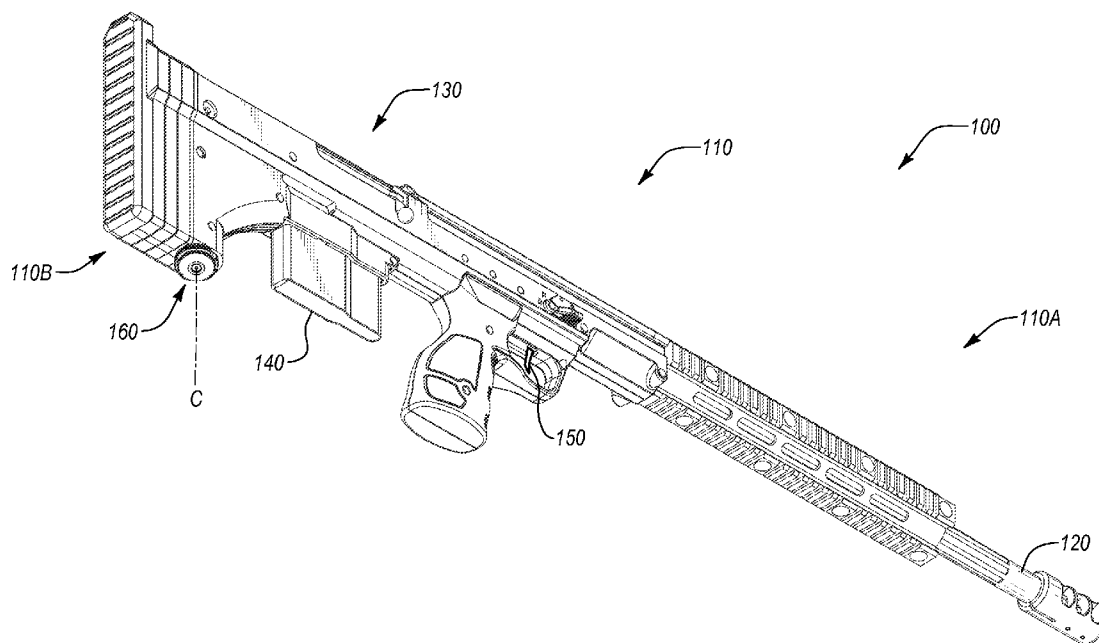

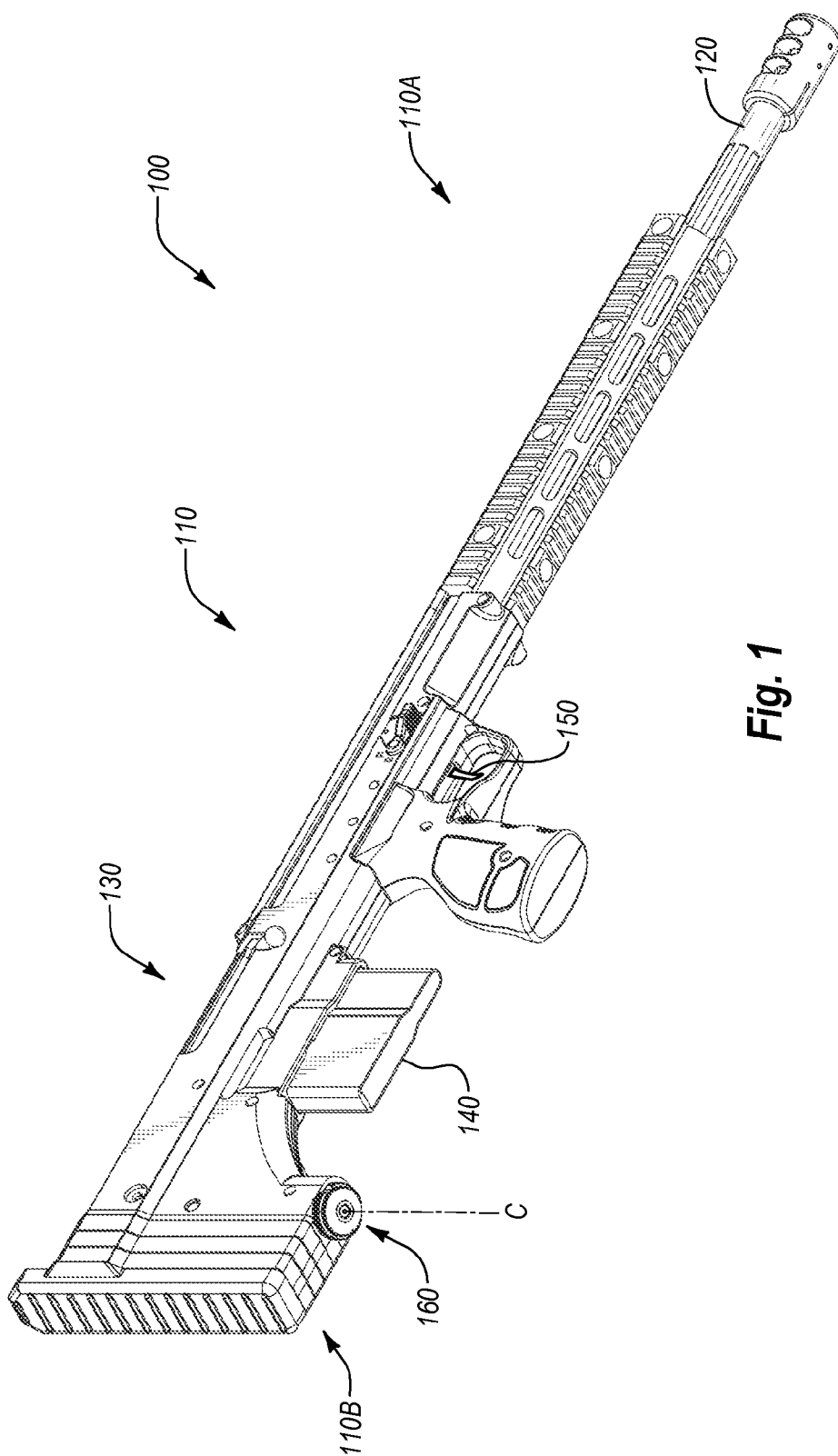

Fig. 1

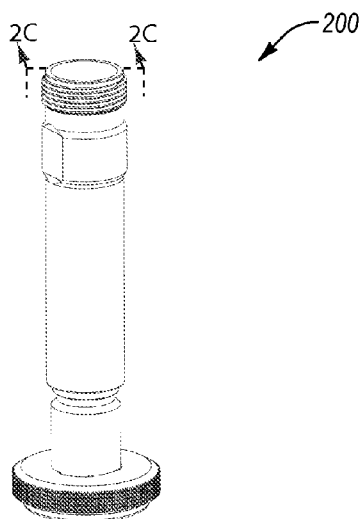

Fig. 2A

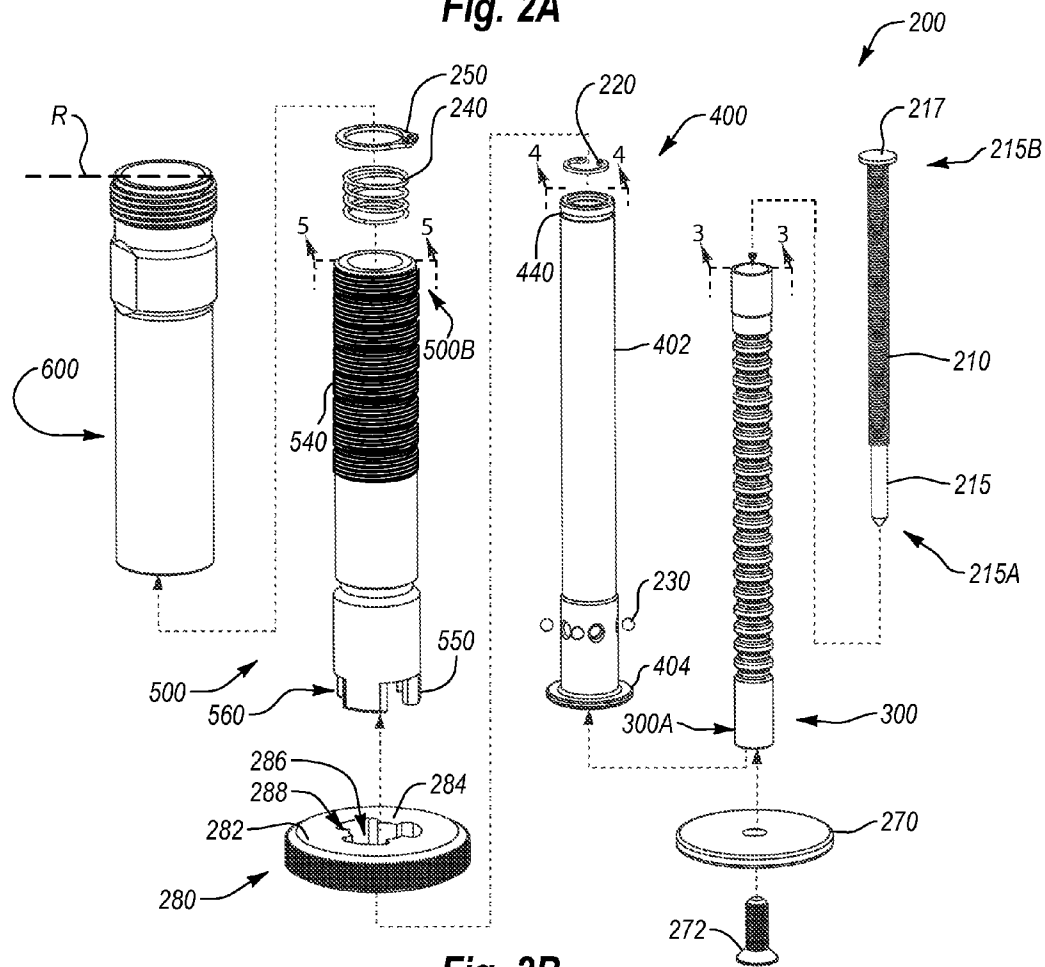

Fig. 2B

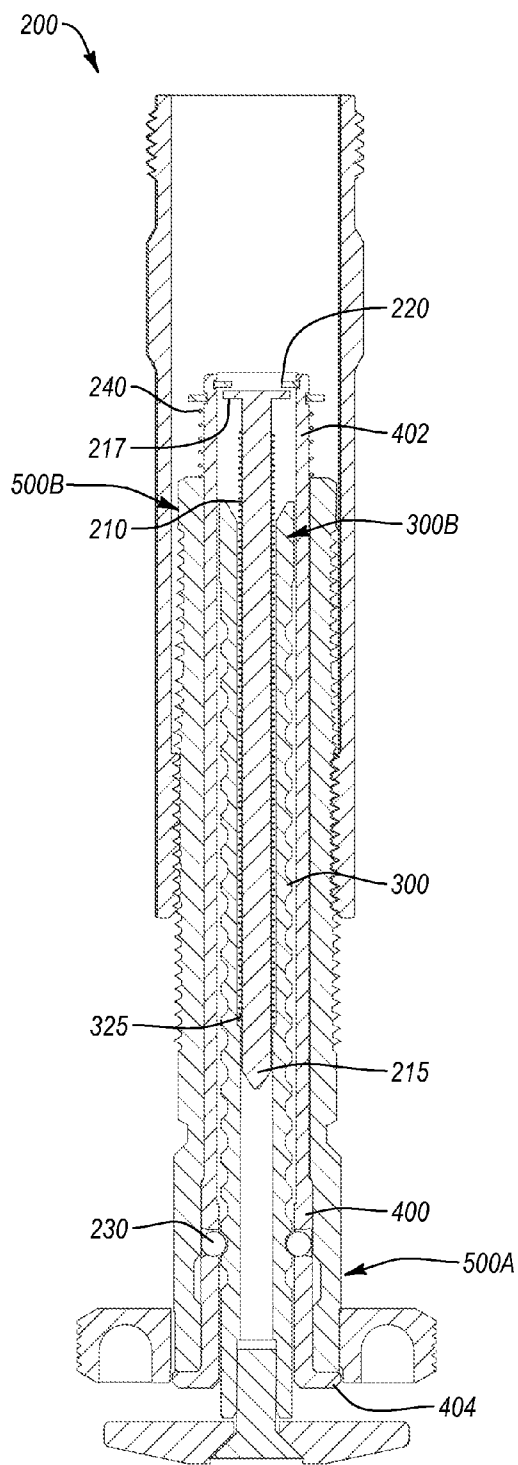

Fig. 2C

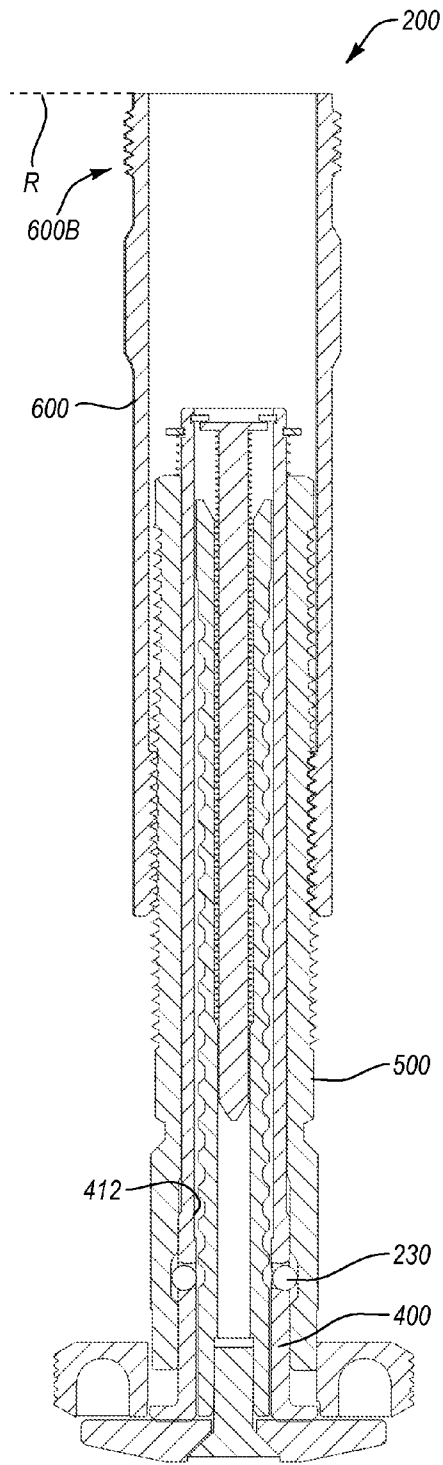

Fig. 2D

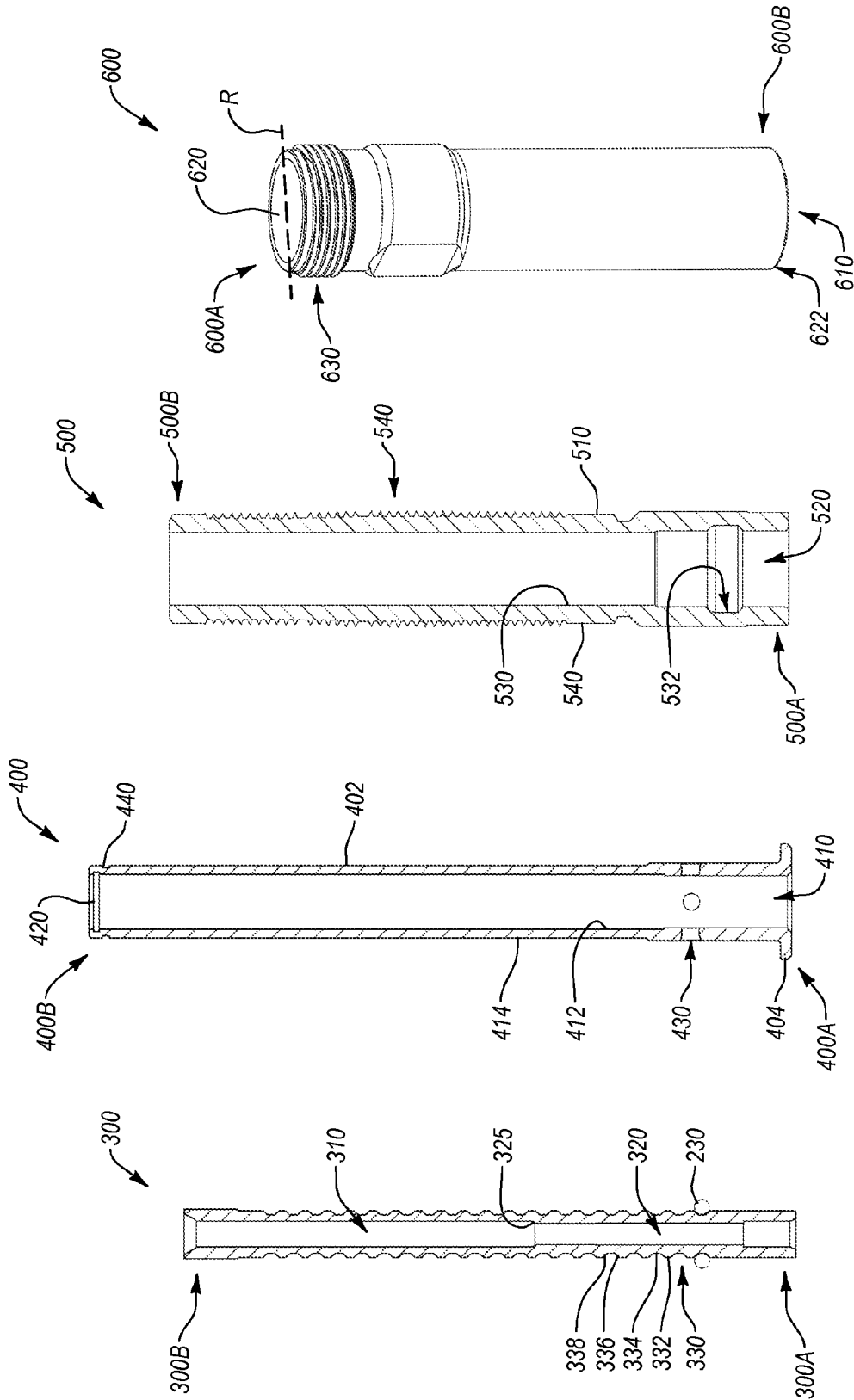

Fig. 6

Fig. 5

Fig. 4

Fig. 3

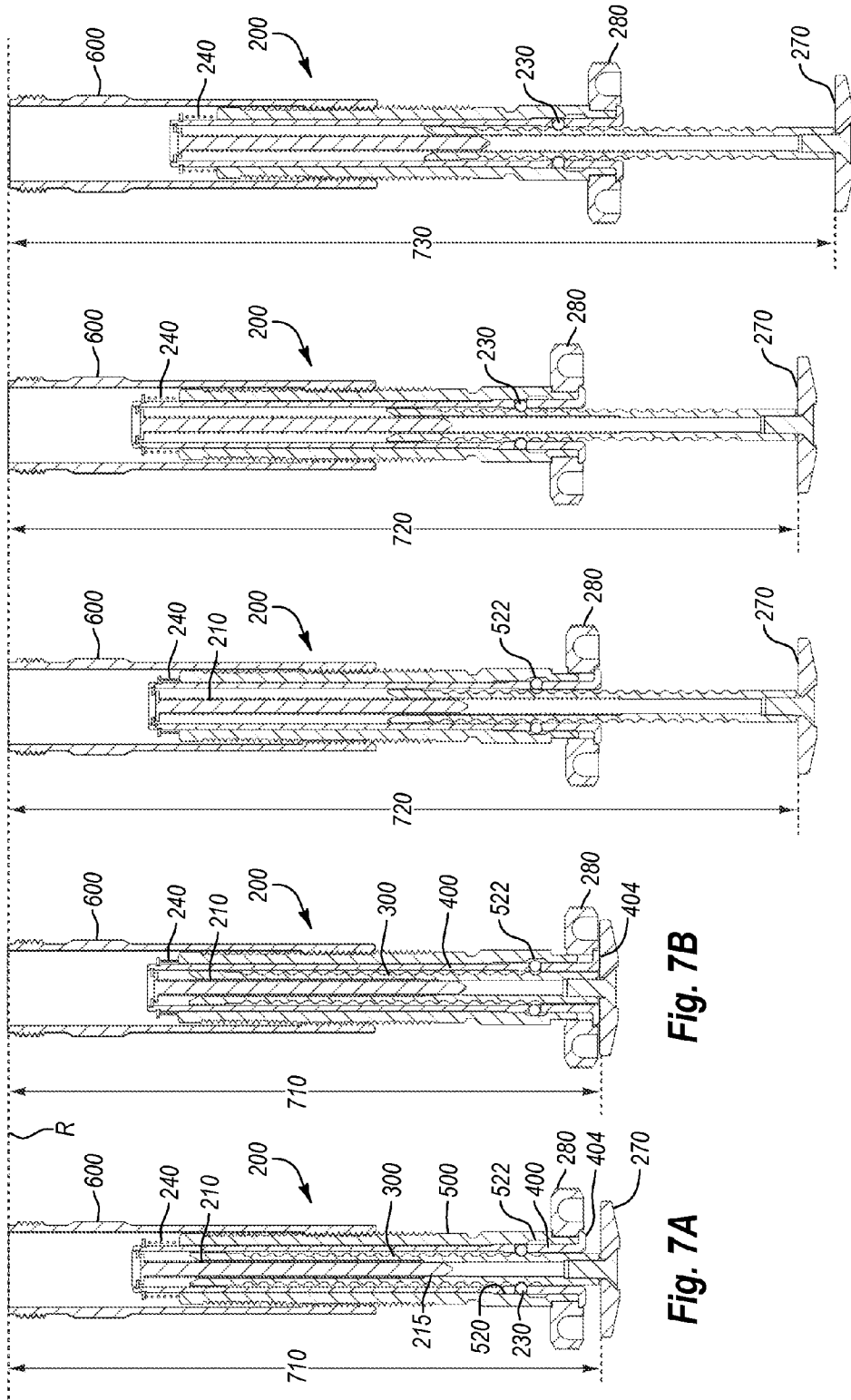

Fig. 7A

Fig. 7B

Fig. 7C

Fig. 7D

Fig. 7E

ADJUSTABLE SUPPORT FOR FIREARMS

BACKGROUND

[0001] 1. The Field of the Invention

[0002] The present application generally relates to adjustable supports for firearms, such as monopods and bipods.

[0003] 2. The Relevant Technology

[0004] Modern firearms make use of cartridges that include a projectile seated in a casing. The casing has an internal cavity defined therein that contains a charge of rapidly combusting powder. A primer is seated in a recess formed in a rear portion of the casing. A hole in the primer casing places the primer in communication with the internal cavity containing the powder. A projectile is seated in the front portion of the casing such that the powder is more or less sealingly contained in the casing between the primer and the projectile.

[0005] An action, such as a bolt action, is used to advance the cartridge into a firing chamber ahead of firing. While in the firing chamber, a firing pin strikes the primer, causing the primer to ignite. The ignition is directed to the powder, which burns within the casing. The powder burning within the casing generates a rapidly expanding gas. The pressure generated by the rapidly expanding gas propels the projectile from the casing and through the barrel of the firearm toward an intended impact point. A sight is used to allow an operator to aim the projectile to the intended impact point.

[0006] For example, optical sights are often used that make use of an aiming point that is projected onto the intended target. Often, the optical sights provide magnification for the operator to view an intended impact point at long range more clearly and thus allow the operator to shoot more accurately. While magnification allows the operator to see intended targets at extended range more clearly, the field of view the operator is able to see at that range can be relatively small. Further, relatively small movements or variations in the orientation of the firearm can result in large variations in the actual impact point of the projectile.

[0007] Accordingly, operators often take several measures to steady the rifle at the desired orientation. Often, a bipod is used with the front stock and the operator then supports the butt end of the stock. While such a system supports the front end of the rifle, small variations in the orientation of the rear end of the rifle can also yield unsatisfactory results.

[0008] The subject matter claimed herein is not limited to embodiments that solve any disadvantages or that operate only in environments such as those described above. Rather, this background is only provided to illustrate one exemplary technology area where some examples described herein may be practiced.

BRIEF SUMMARY OF THE INVENTION

[0009] An adjustable support for a firearm includes an extension shaft having a distal end, a proximal end, a central axis, and a plurality of engagement features formed at a plurality of axial locations between the distal end and the proximal end. A housing assembly is configured to house the extension shaft and defines a reference datum. At least one locking member is operatively associated with the housing assembly and is configured selectively engage the engagement features. An actuator is operatively associated with the housing assembly such that translation of the actuator relative to the central axis moves the locking members into and out of engagement with the engagement features on the extension

shaft. Rotation of the actuator relative about the central axis moves the distal end of the extension shaft away from the reference datum associated with the housing assembly.

[0010] This Summary is provided to introduce a selection of concepts in a simplified form that are further described below in the Detailed Description. This Summary is not intended to identify key features or essential characteristics of the claimed subject matter, nor is it intended to be used as an aid in determining the scope of the claimed subject matter.

[0011] Additional features and advantages of the invention will be set forth in the description which follows, and in part will be obvious from the description, or may be learned by the practice of the invention. The features and advantages of the invention may be realized and obtained by means of the instruments and combinations particularly pointed out in the appended claims. These and other features of the present invention will become more fully apparent from the following description and appended claims, or may be learned by the practice of the invention as set forth hereinafter.

BRIEF DESCRIPTION OF THE DRAWINGS

[0012] To further clarify the above and other advantages and features of the present invention, a more particular description of the invention will be rendered by reference to specific embodiments thereof which are illustrated in the appended drawings. It is appreciated that these drawings depict only typical embodiments of the invention and are therefore not to be considered limiting of its scope. The invention will be described and explained with additional specificity and detail through the use of the accompanying drawings in which:

[0013] FIG. 1 illustrates a firearm into which a monopod can be implemented according to one example;

[0014] FIG. 2A illustrates an assembled perspective view of a monopod according to one example;

[0015] FIG. 2B illustrates an exploded view of the monopod of FIG. 2A;

[0016] FIG. 2C illustrates a cross-sectional view of the monopod of FIGS. 2A and 2B in a first state taken along section 2C-2C of FIG. 2A;

[0017] FIG. 2D illustrates a view of the monopod of FIGS. 2A-2C taken along the same section as FIG. 2A in which the monopod is in a second state;

[0018] FIG. 3 illustrates an isolated cross-sectional view of the extension shaft of FIG. 2B;

[0019] FIG. 4 illustrates an isolated cross-sectional view of the first housing member of FIG. 2B;

[0020] FIG. 5 illustrates an isolated cross-sectional view of the second housing member of FIG. 2B;

[0021] FIG. 6 illustrates an isolated perspective view of the third housing member of FIG. 2B;

[0022] FIG. 7A illustrates a cross-sectional view of the monopod shown in FIGS. 2A-2E in a locked, retracted state;

[0023] FIG. 7B illustrates a cross-sectional view of the monopod of FIG. 7A in an unlocked, retracted state;

[0024] FIG. 7C illustrates a cross-sectional view of the monopod of FIGS. 7A-7B in partially extended, unlocked position;

[0025] FIG. 7D illustrates a cross-sectional view of the monopod of FIGS. 7A-7C in partially extended, locked position; and

[0026] FIG. 7E illustrates a cross-sectional view of the monopod of FIGS. 7A-7D in partially extended, locked position.

tion in which the actuator is rotated while locked to adjust the extension of the distal end of the extension shaft.

DETAILED DESCRIPTION OF THE PREFERRED EMBODIMENTS

[0027] A monopod and rifle stocks including monopods are provided herein that provide both incremental adjustment as well as infinite adjustment for the extension of an extension shaft along an axis relative to a reference datum. The incremental adjustment as well as the infinite adjustment are controlled and manipulated by a single actuator. In at least one example, the actuator is a knob that is moved parallel to the axis to control the incremental adjustment while the knob can be rotated relative to the central axis to provide infinite adjustment. Such a configuration can allow an operator to quickly extend the extension shaft to near a desired extension using the incremental adjustment and then to fine tune the position of the extension shaft with the infinite adjustment to the final desired position. Additional adjustments can be performed quickly using the same process.

[0028] In at least one example, rotation of the actuator is isolated from the extension shaft. Such a configuration can further increase the speed of moving the extension shaft to the desired extension by reducing the likelihood that fine adjustments of the shaft will result in an unintended change in the orientation of the associated firearm due to movement of the extension shaft relative to the ground due to rotation.

[0029] In other examples, the actuator can have a different configuration such that transverse or lateral movement of the actuator or some portion of the actuator relative to the shaft controls incremental adjustment. Such examples can include protrusions that are moved laterally to engage and disengage corresponding recesses in the extension shaft. For ease of reference, exemplary monopod configurations will be discussed that in which locking members are moved radially inward and outward by axial translation of an actuator, though it will be appreciated that other configurations can be provided without departing from the scope of the disclosure.

[0030] FIG. 1 illustrates a perspective view of a firearm system 100 according to one example that includes a stock 110, a barrel 120, an action 130, and a magazine 140. The action 130 is operatively associated with the barrel 110. In the illustrated example, a bolt-type action is shown. It will be appreciated that in other examples, other types of actions, such as pump-type actions, recoil-operated actions, gas-operated actions, as well as any other type of actions can be operatively associated with any types of actions.

[0031] Regardless of the type, cycling of the action 130 moves a cartridge into position to be fired and removes the casing after the cartridge has been fired. For example, forward operation of the action 130 can move a cartridge through a breech and into position with the barrel 130. Thereafter, a trigger 150 can be actuated to release a firing pin in the action 130. The firing pin (not shown) strikes a primer, which ignites gun powder in a casing to propel a projectile through the barrel 120.

[0032] In the illustrated example, the stock 110 generally includes a fore-end 110A and a butt-end 110B. A monopod 160 is coupled to or integrated with the butt-end 110B of the stock 110. As will be discussed in more detail below, the monopod 200 is configured to move between an extended state and a retracted state. For ease of reference, discussion will be made to proximal and distal portions of the monopod

in which a proximal portion is nearer the butt-end 110B than a corresponding distal portion.

[0033] The monopod 160 may be configured to allow an operator to quickly move the monopod 160 to any state between the fully retracted and fully extended states shown and discussed below through the use of incremental and infinite adjustments. In the example shown and discussed in more detail below, the monopod includes an actuator, shown as a knob (and hereinafter referred to as a knob for ease of reference) that controls both the incremental as well as infinite adjustments.

[0034] For example, actuator can be moved parallel to axis C to control incremental adjustments and can be rotated about axis C to control infinite adjustment. Such a configuration can allow for independent incremental and infinite adjustments using the same actuator. One exemplary monopod will be described in more detail below.

[0035] FIG. 2A illustrates a perspective view of a monopod 200 according to one example, FIG. 2B illustrates an exploded view of the monopod 200, and FIGS. 2C and 2D illustrate cross-sectional views of the monopod 200 taken along section 2C-2C of FIG. 2A. As illustrated in FIG. 2B, the monopod 200 generally includes an extension shaft 300, a first housing member 400, a second housing member 500, a third housing member 600, a foot pad 270 and an actuator 280. By way of introduction, the extension shaft 300 is configured to be positioned at least partially within the first housing member 400.

[0036] The monopod 200 includes an extension spring 210, a spring guide 215, and a retaining clip 220 that are configured to be positioned within the first housing member 400 to allow the extension spring 210 to exert a biasing force against the extension shaft 300 to urge the extension shaft 300 distally out of the first housing member 400. The extension of the extension shaft 300 will be described with reference to a reference datum R associated with the third housing member 600, though it will be appreciated that the extension of the extension shaft 300 can be described with reference to any desired structure.

[0037] The first housing member 400 is configured to be positioned at least partially within the second housing member 500. The monopod 200 includes locking members 230, a retention spring 240, and a retaining clip 250. The locking members 230 are configured to be positioned between the first housing member 400 and the second housing member 500. The first housing member 400 and the second housing member 500 include features that house the locking members 230 in such a manner that relative axial movement between the first housing member 400 and the second housing member 500 moves the locking members 230 in to and out of engagement with the extension shaft 300. When the locking members are in engagement with the extension shaft 300, the monopod 200 will be described as being in a locked state. Similarly, when the locking members 230 are out of engagement with the extension shaft 300 the monopod 200 will be described as being in an unlocked state.

[0038] The retention spring 240 and the retaining clip 250 couple the first housing member 400 and the second housing member 500 in such a manner as to allow the first housing member 400 and the second housing member 500 to move between the unlocked and locked state while exerting a biasing force therebetween to move them to a desired one of the unlocked and locked positions.

[0039] In the illustrated example, the retention spring 240 can be configured to bias the first housing member 400 and second housing member 500 toward a locked state. The relative positions described below are provided for ease of illustration only. It will be appreciated that the components can be configured differently, located in different positions and/or moved in different directions to achieve the same functionality described below without departing from the scope of the disclosure. The configurations of the extension shaft 300, the first housing member 400, the second housing member 500, and the third housing member 600 will each be discussed in more detail with reference to FIGS. 3, 4, 5, and 6 in conjunction with a discussion of the assembly of these elements with reference to FIG. 2C.

[0040] FIG. 3 is a cross sectional view of the extension shaft 300 taken along section 3-3 of FIG. 2B. As shown in FIG. 3, the extension shaft 300 generally includes a distal end 300A and a proximal end 300B. As shown in FIG. 3, at least a portion of the proximal end 300B can be generally hollow. In particular, a spring lumen 310 extends distally from the proximal end 300B.

[0041] In the illustrated example, the spring lumen 310 can be sized to receive at least a portion of the ejection spring 210 and the spring guide 215 (both seen in FIG. 2B). The spring guide lumen 320 can be sized to constrain distal movement of at least a portion of the spring guide 215 (FIG. 2A). Accordingly, the spring lumen 310 can have a larger diameter than the spring guide lumen 320 such that a shoulder 325 is formed at the transition between the spring lumen 310 and the spring guide lumen 320. As a result, one or more lumens can extend distally from the proximal end 300B of the extension shaft 300 to house and/or guide the ejection spring 210 and/or the spring guide 215.

[0042] As shown in FIG. 2B, the spring guide 215 generally includes a distal end 215A and a proximal end 215B. The proximal end 215B can have a shoulder 217 formed thereon. The ejection spring 210 can be positioned on the spring guide 215 and in contact with the shoulder 217.

[0043] As illustrated in FIG. 2C, when the monopod 200 is assembled, the spring guide 215 extends proximally of the proximal end 300B of the extension shaft 300. Further, the ejection spring 210 is positioned between the shoulder 217 on the spring guide 215 and the shoulder 325 formed at the proximal end of the spring guide lumen 320 while the extension shaft 300 translates freely with respect to the spring guide 215. As a result, proximal movement of the extension shaft 300 toward the shoulder 217 of the spring guide 215 compresses the ejection spring 210. As the ejection spring 210 is compressed, the ejection spring 210 exerts a biasing force on the extension shaft 300 by way of the shoulder 325. The extension shaft 300 is configured to engage one or more locking member, such as the locking member 230, to lock the extension shaft 300 in a desired axial position within the monopod 200 despite the biasing force.

[0044] More specifically, as particularly shown in FIG. 3, the extension shaft 300 can also include external features configured to engage a locking feature. The external features are positioned at a plurality of discrete axial locations between the distal end 300A and the proximal end 300B. The external features can have any desired configuration to engage any number of locking features in any desired manner to constrain the axial displacement of the extension shaft 300. In the illustrated example, the external features are configured to receive at least a portion of the receiving members.

[0045] In particular, the external features can include a plurality of grooves 330 formed by alternating ridges 332 and recesses 334 configured to receive at least a portion of the locking members 230. For example, the recesses 334 may be sized and shaped to have at least a portion of the locking member seated 230 therein. FIG. 2C illustrates a situation in which the locking members 230 have been moved radially inward to engage the extension shaft 300. As shown more clearly in FIG. 3, as the locking members 230 are moved into engagement with the extension shaft 300, the locking members 230 can be moved radially inward past the ridges 332 and into seating engagement with the recesses 334.

[0046] While locking members 230 are seated in the recesses 334, the ridges 332 can help prevent unintended axial movement of a locking member 230. The grooves 330 can also be shaped to facilitate movement of the locking members 230 into and out of contact with the grooves 330. In particular, each groove 330 can have angled sides 336, 338 that guide the locking members 230 into the groove 330 if an edge of the locking member 230 is slightly out of alignment with the center of a particular recess 334.

[0047] As shown in FIG. 2C, engagement between the locking members 230 and the angled sides 336, 338 (FIG. 3) and between the locking members 230 and the first housing member 400 is sufficient to constrain the axial position of the extension shaft 300 with respect to the first housing 400 in opposition to the biasing force exerted by the ejection spring 210. Accordingly, the extension shaft 300 can be configured to engage a locking member 230 to secure the extension shaft 300 at a desired axial position within the first housing member 400. Structure associated with the first housing member 400 for constraining movement of the spring guide 215 will first be discussed, followed by a discussion of constraining axial movement of the extension shaft 300 in which the spring guide 215 provides a base from which a biasing force is exerted on the extension shaft 300.

[0048] FIG. 4 illustrates a cross sectional view of the first housing member 400 taken along section 4-4 of FIG. 2B. The general structure of the first housing member 400 will first be discussed, followed by a discussion of the configuration of the first housing member 400 for cooperating with the locking members 230, and then a discussion of the configuration of the first housing member 400 for cooperating with the second housing member 500.

[0049] As illustrated in FIG. 4, the first housing member 400 can include a shaft 402 that extends distally from a proximal end 400B. The first housing member 400 can further include a radially protruding portion, such as a flared skirt 404 that is positioned distally from or extends from the shaft 402. In at least one example, an axial length of the shaft 402 can be greater than an axial length of the second housing member 500 (FIG. 2C). In the illustrated example, the flared skirt 404 extends from the shaft 402 adjacent a distal end 400A of the first housing member 400.

[0050] Further, the first housing member 400 has an extension shaft lumen 410 defined therein that extends proximally from the distal end 400A. In the illustrated example, the extension shaft lumen 410 extends from the distal end 400A through the proximal end 400B of the first housing member 400 to form an inner surface 412 and an outer surface 414. In other examples, the extension shaft lumen 410 does not extend completely through the first housing member 400.

[0051] As previously discussed, the first housing member 400 includes structure to constrain the axial movement of the

spring guide 200 (FIGS. 2B, 2C) and to help constrain proximal movement of the spring guide 215 in particular. As illustrated in FIG. 4, a retaining clip receiving groove 420 is defined in the inner surface 412 and is positioned proximally of the distal end 400A. The retaining clip receiving groove 420 can be positioned proximally of the distal end 400A of the first housing member 400. For example, the retaining clip receiving groove 420 can be defined adjacent the proximal end 400B of the first housing member 400.

[0052] As illustrated in FIG. 2C, the retaining clip 220 can be positioned within the retaining clip receiving groove 420 (FIG. 4). When the spring guide 215 is positioned relative to the extension shaft 300 and the extension shaft 300 is positioned within the first housing member 400, the shoulder 217 of the spring guide 215 abuts the retaining clip 220 to constrain proximal, axial movement of the spring guide 215 relative to the first housing member 400. Such a configuration can provide a base from which the ejection spring 210 is able to exert a biasing force on the extension shaft 300.

[0053] Engagement between the locking members 230 and the extension shaft 300 can act to control the ejection of the extension shaft 300, as will now be discussed in more detail with reference to FIG. 2C and FIG. 4. As illustrated in FIGS. 2C and 4, the first housing member 400 includes a plurality of receiving recesses 430 in communication with the extension shaft lumen 410. Each of the receiving recesses 430 is configured to allow a locking member 230 to pass at least partially therethrough and into engagement with the extension shaft 300 as introduced above. Any structure, device, or combinations thereof can be implemented to selectively move the locking member 230 or any other structure in and out of engagement with the extension shaft 300. In the illustrated example, the locking member 230 is moved into engagement with the extension shaft 300 by axial translation of the second housing member 400 relative to the second housing member 500.

[0054] The first housing member 400 also includes structure configured to help control the axial position and translation of the second housing member 500 relative to first housing member 400. As shown in FIG. 4, the first housing member 400 includes an external retaining clip groove 440 defined proximally of the distal end 400A, such as adjacent the proximal end 400B. The retaining clip groove 440 and the flared skirt 404 can cooperate to allow the first housing member 400 to translate axially relative to the second housing member 500 (FIG. 2C) to selectively move the locking members 230 (FIG. 2C) in and out of engagement with the extension shaft 300 (FIG. 2C). These interactions will be discussed in more detail after a brief discussion of an exemplary structure of the second housing member 500.

[0055] FIG. 5 illustrates a cross sectional view of the second housing member 500. As illustrated in FIG. 5, the second housing member 500 includes a shaft 510 that extends at least partially between a distal end 500A and the proximal end 500B. The shaft 510 can be sized to receive the first housing member 400 (FIG. 2C).

[0056] As illustrated in FIG. 5, the second housing member 500 includes a lumen 520 defined therein. The lumen 520 extends from a distal end 500A toward a proximal end 500B of the second housing member 500. In the illustrated example, the lumen 520 extends substantially through the second housing member 500 such that the second housing member 500 has a generally tubular shape thereby causing the second housing member 500 to have an inner surface 530 and

an outer surface 540. The inner surface 530 includes features formed therein that cause axial movement of the second housing member 500 to result in radial movement of the locking members 230 (FIG. 2C). These can include any combination of protrusions, recesses, or any other structure.

[0057] For example, an annular groove 532 can be defined in the inner surface 530 that is in communication with the lumen 510. The annular groove 532 has a larger diameter than the lumen 510 adjacent the annular groove 532. As will be described in more detail below, such a configuration allows the annular groove 532 to receive at least a portion of the locking members 230 (FIG. 2C) therein when the annular groove 532 is moved into alignment with the locking members 230.

[0058] The annular groove 532 can be moved into and out of proximity with the locking members 230 by axial translation of the first housing member 400 relative to the second housing member 500. The coupling of the first housing member 400 to the second housing member 500 will now be discussed in more detail, followed by a more detailed discussion of the interaction between the locking members 230, the extension shaft 300, the first housing member 400, and the second housing member 500.

[0059] Referring now to FIGS. 2B-2C, the first housing member 400 can be secured to the second housing member 500 in any suitable manner. In at least one example, the locking members 230 can be positioned in the receiving recess 430 (FIG. 4). Thereafter, the shaft 402 of the first housing member 400 can be passed through the second housing member 500. As the shaft 402 passes through the shaft second housing member 402, engagement between the inner surface 520 and the annular groove 522 allows the locking members 230 to move radially inward and outward, respectively, through the receiving recesses 430.

[0060] In the illustrated example, the shaft 402 of the first housing member 400 can be passed through the second housing member 500 until the external retaining clip groove 440 is positioned proximally of the proximal end 500B of second housing member 500. The retention spring 240 is then placed over the shaft 402. Thereafter, the retaining clip 250 is then secured to the external retaining clip groove 440. With the retaining clip 250 in place, distal movement of the first housing member 400 is resisted by compression of the retention spring 240 between the proximal end 500B of the second housing member 500 and the retaining clip 250.

[0061] As previously introduced, the first housing member 400 also includes a flared skirt 404. As shown in FIG. 2C, engagement between the flared skirt 404 and a distal end 500A of the second housing member 500 can constrain proximal movement of the first housing member 400 relative to the second housing member 500. Further, as previously introduced, the shaft 402 can be longer than the second housing member 500. As a result, when positioned between the retaining clip 250 and the proximal end 500A of the second member 500 as described above, the retention spring 240 can be positioned to move the flared skirt 404 toward engagement with the distal end 500A of the second housing member 500 as a default position. Accordingly, the first housing member 400 can be moved distally relative to the second housing member 500 by compressing the retention spring 240, such as by drawing the flared skirt 404 away from the distal end 500A of the second housing member 500.

[0062] FIG. 2D illustrates a view of the monopod 200 in which the first housing member 400 has been displaced dis-

tally relative to the second housing member 500 to thereby move the receiving recesses 430 (FIG. 4) into alignment with the annular groove 532 (FIG. 5). The first housing member 400 and second housing member 500 can be thus aligned to allow the locking members 230 to be displaced radially outward into the annular groove 532.

[0063] In particular, the locking members 230 can be displaced radially outward in response to engagement between the locking member 230 and some structure in contact with the inner surface 412 of the first housing member 400. In other examples, biasing members can bias the locking members 230 radially inward or radially outward as desired. In the illustrated example, one such structure can include the ridges 332 of the grooves 330 (both seen in FIG. 3). As a result, while the first housing member 400 is aligned relative to the second housing member 500 as shown in FIG. 2D, the locking members 230 can be displaced radially outward to allow the extension shaft 300 to translate within the first housing member 400.

[0064] Initially, the first housing member 400 can be thus aligned to allow the extension shaft 300, the extension spring 210, and the spring guide 215 to be positioned within the extension lumen shaft 410 as shown in FIG. 2D. After the extension shaft 300, the extension spring 210, and the spring guide 215 are positioned in the second housing member 400, returning the components of the monopod 200 to the relative positions shown can act to release the extension shaft 300 from the first housing member 400.

[0065] The first housing member 400 can be returned to a position relative to the second housing member 500 as shown in FIG. 2C to secure the extension shaft 300 within the first housing member 400. As the first housing member 400 is returned to the position shown in FIG. 2C, engagement between the inner surface 412 adjacent the receiving recesses 430 drives the locking member 230 radially inward and into engagement with the extension shaft 300.

[0066] Accordingly, movement of the first housing member 400 axially relative to the second housing member 500 between the positions shown in FIG. 2C and FIG. 2D, allows the locking members 230 to selectively engage the extension shaft 300 at various axial locations along its length. Selectively engaging the extension shaft 300 in such a manner can thus allow for rapid, incremental adjustments of the position of the distal end 300A extension shaft 300 relative to a stationary reference datum R, such as a proximal end 600B of the third housing member 600.

[0067] As previously introduced, the monopod 200 is also configured to provide infinite adjustment which may be manipulated with the same actuator that controls incremental adjustment. Exemplary structure associated with infinite adjustments will first be discussed, followed by a discussion of the manipulation of the actuator associated with both the incremental as well as the infinite adjustments.

[0068] As shown in FIG. 5, the second housing member 500 also includes features configured to interact with other features of the monopod to provide infinite adjustment of the extension of the extension shaft 300. As shown in FIG. 5, the second housing member 500 can include a threaded portion 540 formed on the outer surface 530 of the proximal end 500B. Referring now to FIG. 2B, the threaded portion 540 can be configured to engage corresponding features in the third housing member 600 such that rotation of second housing member 500 moves the second housing member 500 axially relative to the reference datum R. The extension shaft 300 and

associated components can be coupled to the second housing member 500 in such a manner that the extension shaft 300 and associated components move with the second housing member 500 as it moves axially relative to the third housing member 600. Accordingly, rotation of the second housing member 500 relative to the third housing member 600 moves the extension shaft 300, and thus the distal end 300A thereof, axially relative to the reference datum R.

[0069] FIG. 6 illustrates the third housing member 600 in more detail. As illustrated in FIG. 6, the third housing member 600 can include a distal end 600A and a proximal end 600B. A lumen 610 is defined in the distal end 600A that extends proximally to define an inner surface 620. A threaded portion 622 can be formed on the inner surface 620 that is configured to have the threaded portion 540 of the second housing member 500 (both shown in FIG. 5) coupled thereto.

[0070] The proximal end 600B of the third housing member 600 can include a stock interface 630. The stock interface 630 can have any configuration that allows the third housing member 600 to be secured to the stock 110 (FIG. 1) in any desired fashion, such as to allow the second housing member 500 to rotate relative to the third housing member 600. As previously discussed, rotation of the second housing member 500 (FIG. 5) relative to the third housing member 600 can control the infinite adjustment of the position of the distal end 300A of the extension shaft 300 relative to the reference datum R.

[0071] As shown in FIG. 2B, the footpad 270 can be secured to the distal end 300A of the extension shaft 300 by way of a fastener 272. In other examples, the footpad 270 can be integrally formed with the extension shaft 300. The footpad 270 can be configured to interface with the ground or another stationary surface.

[0072] As previously introduced, the incremental adjustment and infinite adjustments can be made by manipulating a single actuator, such as the knob 280 shown in FIG. 2B. As shown in FIG. 2B, the knob 280 includes an annular portion 282 and knob tabs 284 extending inward from the annular portion 282. The knob tabs 284 form a recess 286 having a diameter that is less than the diameter of the flared skirt 404 and greater than the shaft 402. Such a configuration allows the knob 280 to pass over the shaft 402 and into engagement with the flared skirt 404. Further, such a configuration allows the knob 280 to rotate about the shaft 402.

[0073] As also shown in FIG. 2B, knob slots 288 are defined between the knob tabs 284. The knob slots 288 and knob tabs 284 can be configured to cooperate with corresponding housing tabs 550 and housing slots 560 formed in the distal end 500A of the second housing member 500. In particular, the knob slots 284 can extend through the housing slots 560 and the housing tabs 550 can extend into the knob slots 288. Such a configuration can allow engagement between the knob tabs 284 and the knob slots 288 such that rotation of the knob 280 can result in rotation of the second housing member 500.

[0074] In at least one example, the length of the housing slots 560 can be greater than the thickness of the knob 280. The relative length of the housing slots 560 can allow the knob 280 to move axially independently from the second housing member 500. Accordingly, axial movement of the knob 280 causes the knob tabs 284 to engage and move the first housing member 400 axially while causing minimal or no axial movement of the second housing member 500 axially while rotation of the knob member 280 can result in rotation

of the second housing member **500** while causing minimal or no rotation of the first housing member **400**.

[0075] The axial movement can be sufficient to cause the locking members **230** to move in and out of engagement with the extension shaft **300** to allow for incremental adjustments of the extension of the distal end **300A** of the extension shaft **300** relative to the reference datum R. The rotation of the second housing member **500** causes the second housing member **500**, and thus the distal end **300A** of the extension shaft **300**, to move axially relative to the reference datum R to thereby provide infinite adjustments. As a result, incremental and infinite adjustments can be made using a single actuator. One exemplary process will now be described in more detail below with reference to FIGS. 7A-7E.

[0076] FIG. 7A illustrates the monopod **200** in a locked and fully retracted state. The detailed interaction of the various components has been described in more detail above. For ease of reference, engagement between various components will be described generally, though it will be appreciated that the interactions and engagement may be similar to those described above. The locked aspect of the state shown in FIG. 7A will first be discussed, followed by a discussion of the fully retracted aspect.

[0077] As shown in FIG. 7A, the retention spring **240** can exert a biasing force to move the first housing member **400** proximally relative to the second housing member **500**. Drawing the first housing member **400** proximally places the locking members **230** in engagement with the inner surface **520** adjacent the annular groove **522**. Engagement between the locking members **230** and the inner surface **520** moves the locking members **230** radially inward through the first housing member **400** and into locking engagement with the extension shaft **300**. As shown in FIG. 7A, engagement between the flared skirt **404** and the knob **280** and/or between the knob **280** and the second housing member **500** limits further proximal movement of the first housing member **400** relative to the second housing member **500**. Accordingly, the retention spring **240** can act to move the monopod **200** toward a locked state.

[0078] In the fully retracted position, the foot pad **270** is spaced a first distance **710** from the reference datum R. With the foot pad **270** spaced the first distance **710** from the reference datum R, the extension spring **210** can be compressed between the spring guide **215** and the extension shaft **300** to cause the extension spring **210** to exert an ejection force on the extension shaft **300** that acts to move the extension shaft **300** and thus the foot pad **270** distally away from the reference datum R. Engagement between the locking members **230** and the extension shaft **300** resists the ejection force provided by the extension spring **210**.

[0079] In order to move the monopod **200** from a locked state to an unlocked state, the knob **280** is moved distally as shown in FIG. 7B. As the knob **280** moves distally it does so in opposition to the biasing force exerted by the retention spring **240** described above. Further, as the knob **280** moves distally, it acts on the flared skirt **404** to also move the first housing member **400** distally relative to the second housing member **500**. As the second housing member **400** moves from the position shown in FIG. 7A to the position shown in FIG. 7B, the locking members **230** are able to move radially outward into the annular grooves **522** and thus out of engagement with the extension shaft **300**.

[0080] While the locking member **230** are out of engagement with the extension shaft **300**, the ejection force exerted

by the extension spring **210** moves the extension shaft **300** distally relative to the first housing member **400**, as shown in FIG. 7C. An approximate separation **720** between the foot pad **270** and the reference datum R due to the ejection force can be determined by a proximally acting force acting on the footpad **270**. For example, the approximate separation **720** can be established by contact between the foot pad **270** and the ground or anything else to provide sufficient force. Once the approximate separation **720** has been established, the locking members **230** can be moved into engagement by allowing the knob **280** to move proximally, such as in response to the proximally acting biasing force exerted by the retention spring **240** as shown in FIG. 7D.

[0081] Thereafter, as shown in FIG. 7E, the knob **280** can be rotated to control infinite adjustment resulting in an adjusted separation **730**. In the illustrated example, rotation of the second housing member **500** can be isolated from the extension shaft **300** by the locking members **230**. As previously discussed, the locking members **230** can be spherical members. As a result, the locking members **230** may spin with the rotation of the second housing member **500**, thereby isolating the extension shaft **300** from that rotation, which can help reduce unintended movement of the extension shaft **300** due to rotation.

[0082] Accordingly, a monopod has been discussed herein that provides both incremental adjustment as well as infinite adjustment for the position of an extension shaft. The incremental adjustment as well as the infinite adjustment are controlled and manipulated by a single actuator. In at least one example, the actuator is a knob that is moved parallel to the central axis provide the incremental adjustment. In such an example, the knob can rotated relative to the central axis to provide infinite adjustment. In other examples, the actuator can have a different configuration such that transverse or lateral movement of the actuator or some portion of the actuator relative to the shaft allows for infinite adjustment. Such a configuration can allow an operator to quickly extend the extension shaft to near a desired extension using the incremental adjustment and then to fine tune the position of the extension shaft with the infinite adjustment to the desired position. Additional adjustments can be performed quickly using the same process.

[0083] The present invention may be embodied in other specific forms without departing from its spirit or essential characteristics. The described embodiments are to be considered in all respects only as illustrative and not restrictive. The scope of the invention is, therefore, indicated by the appended claims rather than by the foregoing description. All changes which come within the meaning and range of equivalency of the claims are to be embraced within their scope.

What is claimed is:

1. An adjustable support for a firearm, comprising:
 - an extension shaft having a distal end, a proximal end, a central axis, and a plurality of engagement features formed at a plurality of axial locations between the distal end and the proximal end;
 - a housing assembly configured to house the extension shaft and defining a reference datum;
 - at least one locking member operatively associated with the housing assembly and configured selectively engage the engagement features; and
 - an actuator operatively associated with the housing assembly, wherein translation of the actuator relative to the central axis moves the locking members into and out of

engagement with the engagement features on the extension shaft and wherein rotation of the actuator about the central axis moves the distal end of the extension shaft away from the reference datum associated with the housing assembly.

2. The adjustable support of claim 1, wherein translation of the actuator relative to the central axis is translation parallel to the central axis.

3. The adjustable support of claim 1, wherein translation parallel to the central axis moves the locking member radially inward and outward relative to the extension shaft.

4. The adjustable support of claim 3, wherein the locking member includes a spherical locking member.

5. The adjustable support of claim 1, wherein the engagement features include alternative grooves and ridges.

6. An adjustable support for a firearm, comprising:
an extension shaft having a distal end, a proximal end, a central axis, and a plurality of engagement features formed at a plurality of axial locations between the distal end and the proximal end;

a housing assembly having a reference datum, a first housing member configured to receive at least a portion of the extension shaft, and a second housing member configured to receive at least a portion of the first housing member;

at least one locking member operatively associated with the housing assembly and configured selectively engage the engagement features; and

an actuator operatively associated with the housing assembly, wherein translation of the actuator parallel to the central axis moves the first housing assembly relative to the second housing assembly to move the locking members into and out of engagement with the engagement features on the extension shaft and wherein rotation of the actuator relative about the central axis moves the distal end of the extension shaft away from the reference datum, the actuator being configured to move parallel to the central axis independently of rotation about the central axis.

7. The adjustable support of claim 6, wherein the first housing member includes receiving recesses defined therein configured to receive at least a portion of each of the locking members.

8. The adjustable support of claim 7, wherein the second housing member includes an interior lumen defined therein forming an interior surface, wherein the interior surface has an annular groove formed therein such that alignment of the annular groove and the receiving recesses allows the locking features to move out of engagement with the engagement features on the extension shaft and wherein alignment of the receiving recesses with the inner surface adjacent the annular groove moves the locking features into engagement with the engagement features on the extension shaft.

9. The adjustable support of claim 8, wherein a proximal end of the second housing member includes a threaded portion.

10. The adjustable support of claim 9, wherein the housing assembly further includes a threaded third housing member configured to be threadingly coupled to the threaded portion of the proximal end of the second housing member and wherein rotation of the actuator about the central axis threads and unthreads the second housing member to and from the third housing member.

11. An adjustable support for a firearm, comprising:
an extension shaft having a distal end, a proximal end, a central axis, and a plurality of engagement features formed at a plurality of axial locations between the distal end and the proximal end;

a housing assembly having:

a first housing member having a shaft portion extending distally from a proximal end toward a distal end, a flared portion positioned distally from the shaft portion, a first lumen extending proximally from the distal end and being configured to receive at least a portion of the extension shaft, and wherein a plurality of receiving recesses are defined in the first housing member and are in communication with the first lumen,

a second housing member having a second lumen defined therein extending proximally from a distal end of the second housing member toward a proximal end, the second lumen being configured to receive at least a portion of the first housing member, an annular groove defined in an inner surface of the second housing member, and alternating tabs and slots formed adjacent the distal end of the second housing member;

a plurality of locking members positioned between the inner housing of the second housing member and the first housing member in the receiving recesses; and

an actuator operatively associated with the housing assembly, the actuator being configured to move the first housing member parallel to the central axis relative to the second housing member to move the receiving recesses into and out of alignment with the annular groove in the second housing member to move the locking member into and out of engagement with the engagement features on the extension shaft, the actuator being further configured to rotate the second housing member relative to the central axis independently of movement of the first housing member parallel to the central axis.

12. The adjustable support of claim 11, wherein further comprising a biasing member between the distal end of the first housing member and the extension shaft.

13. The adjustable support of claim 11, wherein the shaft of the first housing member extends proximally of a proximal end of the second housing member.

14. The adjustable support of claim 13, further comprising a biasing member positioned between the proximal end of the first housing member and the proximal end of the second housing member.

15. The adjustable support of claim 11, wherein a proximal end of the second housing member includes a threaded portion.

16. The adjustable support of claim 15, further comprising a third housing member having a threaded distal portion configured to have the threaded portion of the proximal end of the second housing member coupled thereto, wherein the rotation of the actuator about the central axis threads and unthreads the second housing member from the third housing member to move the distal end of the extension shaft independently from extension of the extension shaft relative to the first housing member.